

Patrick Lindecker (F6CTE) the 11th of November 2006
Corrected by Bill Duffy (KA0VXK)

DIRECT CONVERSION RECEIVER WITH COMPUTERIZED SSB DEMODULATION

If you have a powerful PC (700 MHz or more) equipped with a quality, stand alone sound card, and you are interested in building a small simple receiver, then you could test your first SSB receiver with computerized tuning. You could also connect to the decoding software Multipsk through a TCP/IP link. At last, it will give you the opportunity to use your old crystals.

The reception system introduced in this paper includes a very simple "DSB" direct conversion receiver and software to manage the potential of this receiver.

Hardware requirements:

This software works on PC at 700 MHz or more, under Windows 95, 98, NT or XP. Lower speed PC's (<700 MHz) are too slow to be suitable for this program.

Others components are also necessary:

- a direct conversion receiver at the center of this article or an other DSB receiver if the AF output is not filtered or is low pass filtered at 20 KHz or more (and not, as usual, 3 KHz),
- a standalone "full-duplex" sound card (not an "on board" sound card, these produce static. This appears to be caused by an imprecise clock frequency.

Description of the Multidem program

This program ("freeware") allows one to:

- extract any USB, LSB or AM transmission present in the AF band of a direct conversion receiver, up to 20 KHz,
- to band-pass filter the received signal,
- afterwards, to forward it to amplified loudspeakers and to Multipsk (for decoding) through a TCP/IP link.

To accomplish this, the program manages the PC sound card, the card being linked to a direct conversion receiver via a cable connected to the AF output of the DSB receiver and to the Microphone connector of the sound card.

Note: MultiDem and MultiPSK can be downloaded from the author site: <http://f6cte.free.fr>

This software digitizes (to 44100 samples/sec, 16 bits) the signal coming from the DSB receiver. This makes possible the selection of a signal on the waterfall and demodulates this signal for a USB, a LSB or an AM reception according to the transmission, to receive (CW in USB, digital in USB, phone in LSB or AM). The AF signal resulting from this demodulation is now decimated to 11025 samples/sec, 16 bits, band-pass (200-3300 Hz, for example) filtered, before being forwarded under two possible forms:

- acoustic by directing the signal to the sound-card output,
- digital by directing the signal to the Multipsk software, the transmission protocol being TCP/IP type, as described hereafter.

TCP/IP protocol between MULTIDEM and MULTIPSK: each sample is sent as a byte (8 bits). The bytes transmission is done through the port 3020 and the host address 127.0.0.1. The bytes transmission frequency is equal to 11025 per second. There is no control from Multipsk. It is better to send data by

group (200 bytes per group, for example) to avoid a CPU saturation. This protocol is free: other software than Multipsk could use this protocol to receive samples coming from MULTIDEM. For the TCP/IP link, one could take inspiration from the "Multipsk_client" software available (source and .EXE) on the author's site: <http://f6cte.free.fr>

To summarize: this software permits one to select the received frequency (which defines an AF bandwidth from 0 to about 3000 Hz) between 0 and +/- 20 KHz compared to the crystal frequency. It is a computerized tuning. For example, if the crystal is selected for a 3579 KHz frequency, the reception will be done between 3559 et 3599 KHz (40 KHz of bandwidth).

Finally, several band-pass filters are proposed.

IMPORTANT: in a DSB receiver, the user can't know without going into the subject if he is listening a USB or a LSB transmission because, in this type of receiver, there is a folding of the negative frequencies on the positive frequencies around the reception frequency.

Use example

The user begins by placing his receiver (electrically supplied) in a metallic box and distant from the PC. The receiver is connected to an exterior antenna.

The receiver output cable is connected to the sound card input (preferably, the "Microphone" plug). The sound card output is connected to amplified speakers.

Multidem is started.

By using the computerized frequency tuning of Multidem, the user could possibly listen to transmissions in LSB, USB, DSB or AM in the reception band of 20 KHz on both sides of the DSB receiver reception frequency. It is reminded that in a DSB receiver, the type of signal (USB or LSB) is not initially known.

According to the level displayed on Multidem (in %), the AF gain will be adjusted on the mixer (the target would be a level between 15 and 40 %).

With the potentiometer P1 of 1000 ohm, the HF gain will be reduced if the receiver saturates on strong signals, which leads of reception of broadcast commercial AM stations outside of the reception band, through a parasitic envelope detection. This phenomenon rather appears in the evening, or all time if one is located, as the author, close to a broadcast AM transmitter.

It can be easily seen on the waterfall because the bandwidth covered by these parasitic AM demodulations, corresponds to the first 3 KHz. Note that it remains on the waterfall 17 KHz non polluted on the 20 KHz.

If the QSO is Digital, the user, from Multipsk, will click on the button "Mdem" to open a window dedicated to the interface with Multidem. Then he will click on the button "Link opening". This will allow Multidem to connect to the Multipsk server (which is listening). Afterwards, from Multidem, the user will click on the button "Connection", which will permit this program to connect the Multipsk server. Afterwards, the "Mdem" will be closed.

Now, Multipsk will decode all the samples sent by Multidem.

BLOCK DIAGRAM

Here is the block diagram of the application

F6CTE direct conversion receiver Version 1

Block diagram

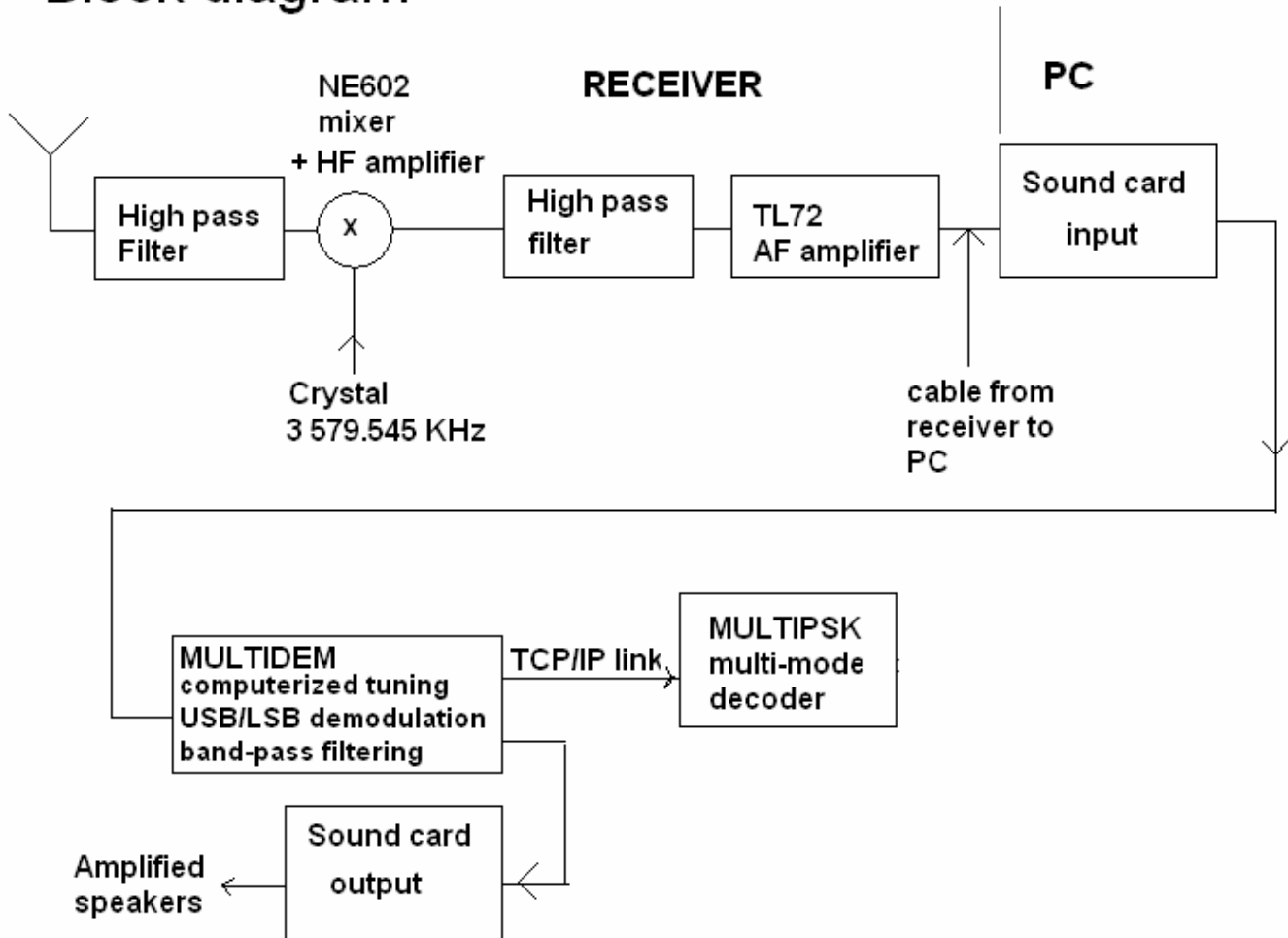

SCHEMATIC OF THE CONNECTIONS

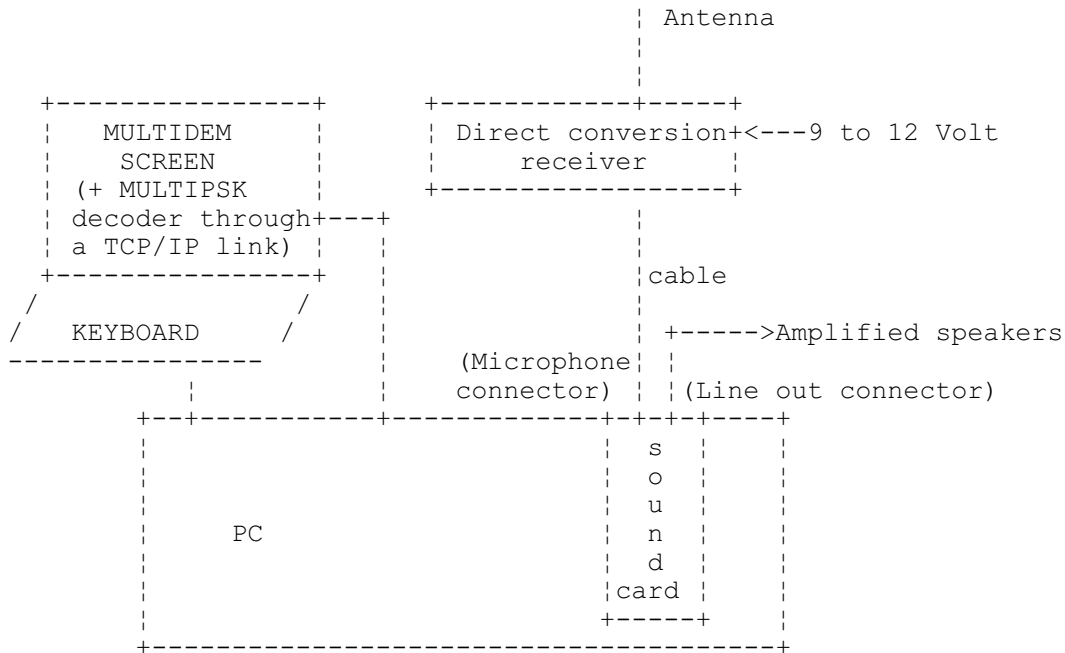

OUTSIDE CONNECTIONS OF THE SOUND CARD

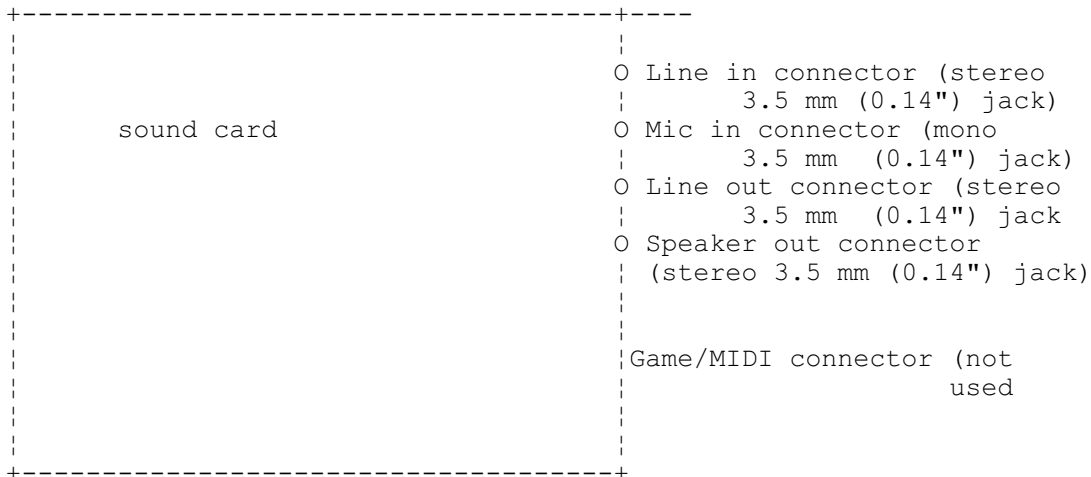

For input, the Mic-in connector must be, preferably, used because an amplifier is integrated. If the Line in connector is used, the output signal will be too weak.

Note 1: on some sound cards, Line in input and Mic input are inverted.

Note 2: on most of the sound cards, there is no Speaker out connector. In that case, it is necessary to use the Line in plug connected to amplified speakers.

Radio receiver working

Generalities

The receiver is a direct conversion type (no intermediate frequency). It is designed to receive a frequency band around the crystal frequency.

It is a DSB ("Double Side Band") receiver, which means, given the following hypothesis:

- the crystal frequency is at 3579 KHz,
- the sound card disposes (as usual) of an anti-aliasing low pass filter at 20 KHz,

that it will be received all carrier located between $3579 - 20 \text{ KHz} = 3559 \text{ KHz}$ and $3579 + 20 \text{ KHz} = 3599 \text{ KHz}$.

It is not a SdR receiver in the usual meaning.

Note about the SdR receivers

In this type of receiver, the received signal is sampled thanks to a crystal or a DDS signal, having an oscillation frequency equal to 4 times the frequency of the signal to demodulate. It is done in such a configuration that it is found in output two base band orthogonal signals (i.e. the scalar product is equal to 0 or, in other words, they are uncorrelated). They are called I (for "In-phase") and Q (for "Quadrature"). The knowledge of these two signals gives the ability to determine the amplitude and the phase compared to the sampling instants. It is reminded that the phase is undetermined if one only has one signal (as only the amplitude can be measured). The determination of the amplitude and the phase comes to the resolution of a problem at 2 unknowns (amplitude / phase) where it needs 2 independent equations (or 2 measures).

In presence of a carrier modulated by an AF signal, simplifying, one would have at the SdR receiver output:

$I = A \cos(2.\pi.df.t)$ and $Q = A \sin(2.\pi.df.t)$ with df : the AF signal frequency

It can be noted that the amplitude is computed by $A = \sqrt{I^2+Q^2}$ and the phase by

$\varphi = \tan^{-1}(Q/I)$, this (equivalent) representation) being more physical than the first (I and Q).

It is important to underline that at the first reception of a carrier, it will not know if its frequency is located below or above the crystal frequency. Besides, if the carrier frequency is located below the crystal frequency and if it is modulated in USB, it will be seen as a LSB transmission.

This will not occur with a SdR receiver, because the phase information is known. This means, in this case, that the frequencies located below the crystal frequency could be distinguished from the ones located above.

Working of this type of receiver associated with the MultiDem software

Preliminary note: x and . means multiplication

Let's suppose that:

- the crystal frequency be f_0
- the received signal be a pure carrier (non modulated) at the frequency f (or w in term of pulse), with:
 $f_1 = f_0 + df$ with $df = 3 \text{ KHz}$ or $w_1 = w_0 + dw$ with $dw = 2.\pi.df$

the mixer (NE602) multiplies the carrier generated by the crystal $x(t) = A . \cos 2.\pi.f_0.t$ by the received signal $y_1(t) = B . \cos(2.\pi.f_1.t + \rho_1)$ with ρ_1 the start phase.

The NE 602 output voltage is equal to: $V(t) = A . \cos 2.\pi.f_0.t \times B . \cos(2.\pi.f_1.t + \rho_1)$

$V(t) = A.B/2 \times [\cos(2.\pi.(f_1-f_0).t + \rho_1) + \cos(2.\pi.(f_1+f_0).t + \rho_1)]$

The frequency f_1+f_0 of about 7 MHz will be blocked, in our case, by the operational amplifier (which has a bandwidth at the unit gain of 3 MHz) and, especially, by the sound card which anti-aliasing filter blocks frequencies from 20 KHz (at 22 KHz, the level is residual).

Let's note $df = f_1-f_0$

Remaining is the component $A.B/2 \times \cos(2.\pi.df.t + \rho_1)$ which will appear as a carrier at df Hz on a spectrum analyzer.

Let's suppose that an other carrier $y_2(t) = C . \cos(2.\pi.f_2.t + \rho_2)$ be located at $-df$ of the crystal frequency ($f_2 = f - df$) hence symmetrically compared to $f_1=f + df$

After multiplication in the mixer and filtering, it will be found the signal $A.C/2 \times \cos(-2.\pi.df.t + p2)$
 Now $A.C/2 \times \cos(-2.\pi.df.t + p2) = A.C/2 \times \cos(2.\pi.df.t - p2)$ is a signal which will also appear as a carrier at df Hz on a spectrum analyzer.
 The 2 carriers will be added at df Hz. On congested bands, this would be harmful when receiving. Hereafter, it will be found a small explanatory diagram:

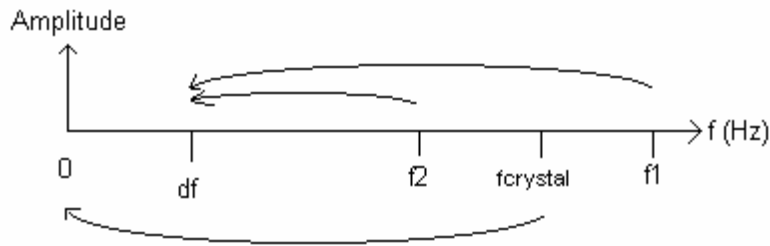

Note: in a standard Ham receiver, if $f_{crystal}=455$ KHz (last mixer), it is selected (thanks to a filter) the band between $f_{crystal}$ and f_1 for USB and between f_2 and $f_{crystal}$ for LSB. There is no mixture.

Let's consider now, that instead of a pure carrier we will have a frequency band represented by a triangle which peak represents 0 Hz for the considered band. It is supposed that the transmissions are done in USB (each triangle has its peak at left side). By applying the above diagram, it can be seen that the transmission which frequency is inferior to $f_{crystal}$ is reversed at the reception (it will be seen as LSB).

Below are two diagrams which explain the reversal:

1) before the frequency relocation done by the receiver

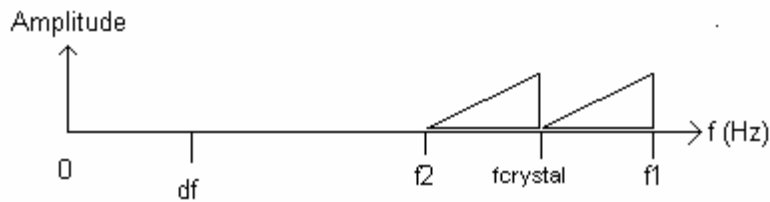

2) after the frequency relocation done by the receiver

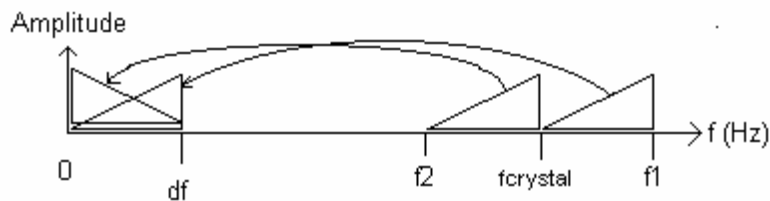

Let's suppose now:

- that the frequency band of the first transmission be located between f_1 and f_2 with $f_2 > f_1$ and $f_1 > f_{crystal}$,
- and that the transmission be a phone USB one (so $f_2 = f_1 + 3$ KHz).



The frequency relocation will be done as previously but the 0 Hz of the frequencies band will be shifted compared to the position $f=0$ Hz. All the frequencies being shifted to the high notes, the listening will be at the best unpleasant and the at worst impossible. Hereafter, it will be found a diagram of this relocation.

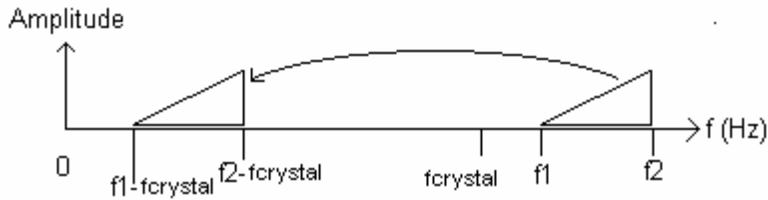

The user must, to give the transmission intelligible, relocate the frequencies band located between $f1-fcrystal$ and $f2-fcrystal$ to the band located between 0 and $f2-f1$. This is what he will do at Multidem level, using the computerized tuning (spin button or mouse wheel) or pointing the frequency " $f1-fcrystal$ " with the mouse on the waterfall, all this after having selected the USB mode.

Once the frequency " $f1-fcrystal$ " selected, the software does the following operations, if the user has selected "USB":

- relocation of the band located between " $f1-fcrystal$ " and " $f2-fcrystal$ " to the base band 0 to " $f2-f1$ ". This will be done thanks to a FFT ("Fast Fourier Transform") followed by a rotation of frequential components to the point " $f = 0$ Hz" and, at last, a return to the time domain, doing a reverse FFT. **Note:** it would have been possible to relocate this band by multiplying it by $f1-fcrystal$. But one would have found terms in $(f1-fcrystal) + (f2-fcrystal)$ which it would be possible to eliminate but also terms in $2x (f1-fcrystal)$ which could be found in the pass band if $f1-fcrystal$ be weak.

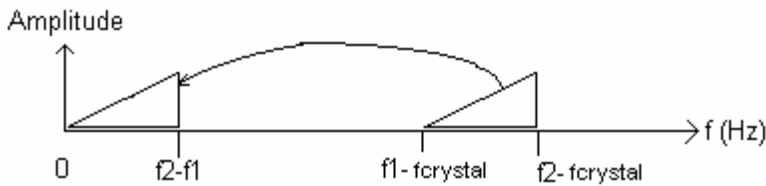

- the base band signal is digitally low pass filtered before to operate the decimation of the sampling frequency from 44100 to 11025 samples/sec. The filtering done here is destined to avoid components over 5512.5 Hz ($11025/2$) to fold on the 0 – 5512.5 Hz band (it is an anti-aliasing filter). The decimation permits, afterwards, to filter in the time domain without big computing need.
- the base band signal can be, afterwards, band pass filtered.

If the user has selected "LSB", the software reverses the base band spectrum (see diagram below). Hence the direction of reception is reversed. The reversal operations are complex and are not exposed in this paper.

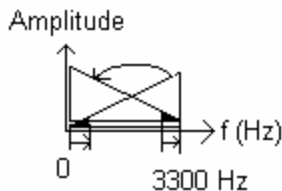

Description of the receiver

To support explanations, one will refer to the diagram of the receiver and to the principle diagram.

Power Supply

Its goal is to supply a 6 V voltage continuous and regulated.

The source of the power is a power pack, "+" at the center, with selection of the "9 V" position.

Note polarity carefully

However, in case of error in the polarity, the diode D1 will prevent the polarity reversal at the circuit level.

A led indicates the presence of current.

The consumption is about 11 mA.

As indicated in the diagram, the supplied voltages, from the 7806 regulator and from the resistors bridge R2/R3 are 6 V and 3 V.

H.F/A.F part

The HF signal is collected from an Ham antenna. If not available, an antenna made up, for example, by several meters of wire located at the exterior will be enough.

The HF gain is adjustable by the potentiometer P1. This adjustment is compulsory, this because, if the HF signal is too strong (rather on the evening), there is an intermodulation with very powerful signals and an envelop (AM) detection appears. In this case, the gain must be reduced.

The HF signal collected concerns all the radio frequencies. The frequencies we are interested in are filtered by the high pass filter L1/C2, serving as band-pass filter around 3,6 MHz but allowing reception on 7 and 10 MHz (with the appropriate crystal).

This filtered signal is amplified by the NE602 internal amplifier (18 dB of gain).

The oscillator is made up of the crystal Q1 at 3579 KHz and the components C4, C5 and R4 and the internal NE602 components.

The signal generated at 3579 KHz is mixed with the input signal in the NE602 by multiplication of these signals. At the output, it is found an AF signal centered around 0 Hz (with superior and inferior lateral bands mixed) and other mixing HF products (at 2 x 3579 KHz) which will be eliminated by the TL72 OA (Operational Amplifier), which transmission band at the unit gain is equal to 3 MHz.

The AF signal is high-pass filtered by the elements C6/R5 then amplified by the first OA of the TL72. The AF signal is, afterwards, sent to the Line or Microphone PC sound card input. It must be noted that the sound card input integers a low pass filter at 20 KHz, called "anti-aliasing filter".

The signal is amplified by a factor 100 by the second OA. The output signal can be used as a test signal or for a frequency meter.

Radio receiver assembling

The assembling operations of the electronic circuit are given in a chronological order:

- 1) From the "typon" ("copper" circuit), it will be realized the tined "simple side" printed circuit. It will be noted that the circuit is 82.5 x 57 mm (3.26" x 2.24") dimensions. Four circles indicate the location of the mounting screws.

The continuity of the tracks and their isolation the ones compared with the others can be verified. In fact, when realizing the printed circuit, it can appear tracks lightly nibbled and smudges from a track to the other.

Once the circuit checked, it should be drilled:

- * at 1.3 mm (0.051") the two big pads of the fuse-holder,
- * at 1 mm (0.039"), the pads corresponding to the 7806, the 1000 uF capacitor, the 1N4001 diode and the 3 terminal connectors,
- * at 0.8 mm (0.031") for the other pads.

Note: it will be preferable to mount the circuit in a metallic box connected to the negative of the power supply.

2) The components will be installed on the circuit, according to the component schematic diagram then they will be soldered on the pads.

Attention:

- * it is preferable to install the integrated circuits NE602 and TL72 on DIL 8 pins supports, so as to easily change them in case of failure,
- * it is strongly advised to install the crystal on a two pins support "tulip" type, so as to easily change the crystal (it is important in this type of device to easily change the crystal.)
- * the 1N4001 diode will be installed in the good direction: the cathode (line on the component symbolization) is marked on the diode and on the component schematic diagram,
- * the regulator will be installed in the good direction: the bold line on the component symbolization represents the metallic face of the component,
- * the diode and the regulator will be rapidly soldered,
- * when installing the tantalum capacitor (1 microFarad), the polarity will be respected ("+" or "-") indicated in the component schematic diagram, the polarity + being marked on the capacitor,
- * the I.C (Integrated Circuit) support will not be soldered with the IC installed on it.

When installing the IC on the soldered support, attention to the installation direction (the small circle in the IC component schematic diagram must correspond to a semi-round cut or to a point at one end of the IC).

The components to install on the board are the following:

- . 3 terminal connectors equipped with vertical screws for two terminals separated by a space of 5.08 mm (0.2")
- . 1 fuse-holder for printed circuit: for 5 X 20 mm (0.2" x 0.79") fuse,
- . 1 quick fuse 100 mA, 5 x 20 mm (0.2" x 0.79")
- . 1 vertical capacitor 1000 microFarad (uF),
- . 1 tantalum capacitor 1 microFarad (uF),
- . 1 polyester (or equivalent) capacitor 150 nF
- . 3 polyester (or equivalent) capacitors 100 nF
- . 2 ceramic capacitors 330 pF
- . 1 ceramic capacitor 270 pF
- . 1 self 6.8 microHenry
- . 1 crystal 3579 KHz

- . a "tulip" support with two pins to install the crystal
Note: 3.5 MHz and 10 MHz crystals could also be used.
 The available crystal in 3.5 MHz are the following:
 - 3579 KHz: CW and digital modes,
 - 3668 KHz: phone QSO.
 The old crystal (military origin) could also be used. For example, the author uses a crystal at 7006 KHz to cover from 6986 to 7026 KHz (for CW).

- . 2 resistors 1 Mohm, 1/4 Watt, 5 %
- . 2 resistors 27 Kohm, 1/4 Watt, 5 %
- . 3 resistors 10 Kohm, 1/4 Watt, 5 %
- . 1 resistor 4.7 Kohm, 1/4 Watt, 5 %

- . a potentiometer 1 Kohm (HF gain)

- . 5 wire straps (insulated, acting as a bridge between two pads which could not be connected in an other way)

- . 1 regulator 6 V (7806) in TO202 or TO220 box

- . 1 rectification diode 1N4001 (or 1N4002, 3, 4)

- . 1 led 5 mm (0.2"),

- . 1 integrated circuit TL072 (2 OA weak noise in an electronic case)

- . 1 integrated circuit NE 602 (oscillator, amplifier and mixer) or NE 612 (SA612)

- . 2 DIL 8 pins supports for the NE602 and TL072

At this point, the printed circuit is finished and the circuit has been checked. All that remains is to connect the power supply, to complete it and to interface it with the PC to bring it all together..

Other components required are :

* for the box:

- . a metallic box (preferably in steel),
- . 4 metallic columns and the necessary screws and bolts,
- . 4 rubber "feet",

* for the electric supply:

- . one pluggable supply (power pack), with "9 V" position and output on a mono 3.5 mm (0.14") jack (+ at the center),
- . 1 plastic female jack 3.5 mm (0.14") mono for box.

Note: the author has not expected an unipolar switch on the power supply, because it is enough to disconnect the jack to switch off the electric current.

Mounting: the female jack will be installed on the box. Afterwards, the mobile exterior blade on the jack will be connected to the input "+" terminal of the connector "Supply 9 volt" (see the component schematic diagram) on the printed circuit. The ground blade on the jack will be connected to the input "-" terminal of the connector "Supply 9 volt".

* for the receiver / PC sound card link

- . at least 2 m of shielded coaxial cable ended with a 3.5 mm (0.14") mono jack. The "+" must correspond to the jack end.

Instructions for bringing the receiver into operation with MultiDem

The "Multidem" software has been installed on the PC.

The radio receiver is connected to the PC through the sound card Line or Microphone (preferably) input. The receiver and the PC are stopped.

An amplified speaker is connected to the "Speaker" or "Line out" sound card plug.

Preliminary checks

The circuit as a whole must be checked, element by element. A connection error, an inversion of component, etc... is enough to destroy the integrated circuits. It will be noted, by the way, that the NE602 is particularly fragile. Check that the terminals are well screwed and that solderings are correctly done. If a solder joint is suspected to be bad, the involved IC can be removed and the resistors value ending to the IC checked.

The potentiometer P1 (HF gain) is at mid-position.

Note: if it is mounted in the circuit, the maximum gain is obtained when turned left up. If it is mounted on the box, it will be connected so as the maximum gain be obtained when turned right up.

Power supply checking

Let's supply the receiver.

The presence of the 6 V (at the C1 terminals) and 3 V (at the R3 terminals) must be checked.

In case of failure: check the presence of voltage at the output of the power pack, then the direction of connection of the 1N4001 diode, and at last the 7806 regulator working.

HF/AF part checking

It will be checked that the NE602 produces oscillation by listening to the crystal generated carrier at 3579 KHz, on the user transceiver.

The PC is switched on and Multidem is started up. If necessary, select the suitable sound card. It can be, normally, heard a light noise and the level of the received signal ("Level" label) must be superior to 0 %. In the contrary case, it will be necessary to check that the HF gain is maximum (on the potentiometer P1). The gain on the mixer associated to the sound card will be increased.

If the received signal level is saturated (the pseudo-led lights), it will be necessary to reduce the HF gain (on the potentiometer P1). The mixer gain could be also reduced.

To select a reception frequency, it is possible to click on the waterfall, use the spin button called "Frequency" or to use the mouse wheel to relocate the frequency. Perhaps, a CW or a digimode (often RTTY) transmission could be heard.

If it is a digital transmission, Multipsk will be started up and the connection to Multidem will be done.

The standard way to have a permanent full-duplex connection between Multidem and Multipsk (the server) is the following:

- 1) from Multipsk, click on the button "**Mdem**", then click on the button "**Link opening**". This will permit for Multidem to connect to the Multipsk server (which is listening),
- 2) from Multidem, click on the button "**Connection**", which will permit to this program to connect the Multipsk server. Now that the TCP/IP link is established, the byte counter "**N=**" is going to evolve.
- 3) To start-up the decoding, this "Mdem" window must be closed.

IMPORTANT: the PC ground terminal must be connected to the installation earth, otherwise the PC parasitic risk to be incompatible with the receiver working.

For a detailed use of the Multidem and Multipsk programs, please report to the information help of these softwares.